

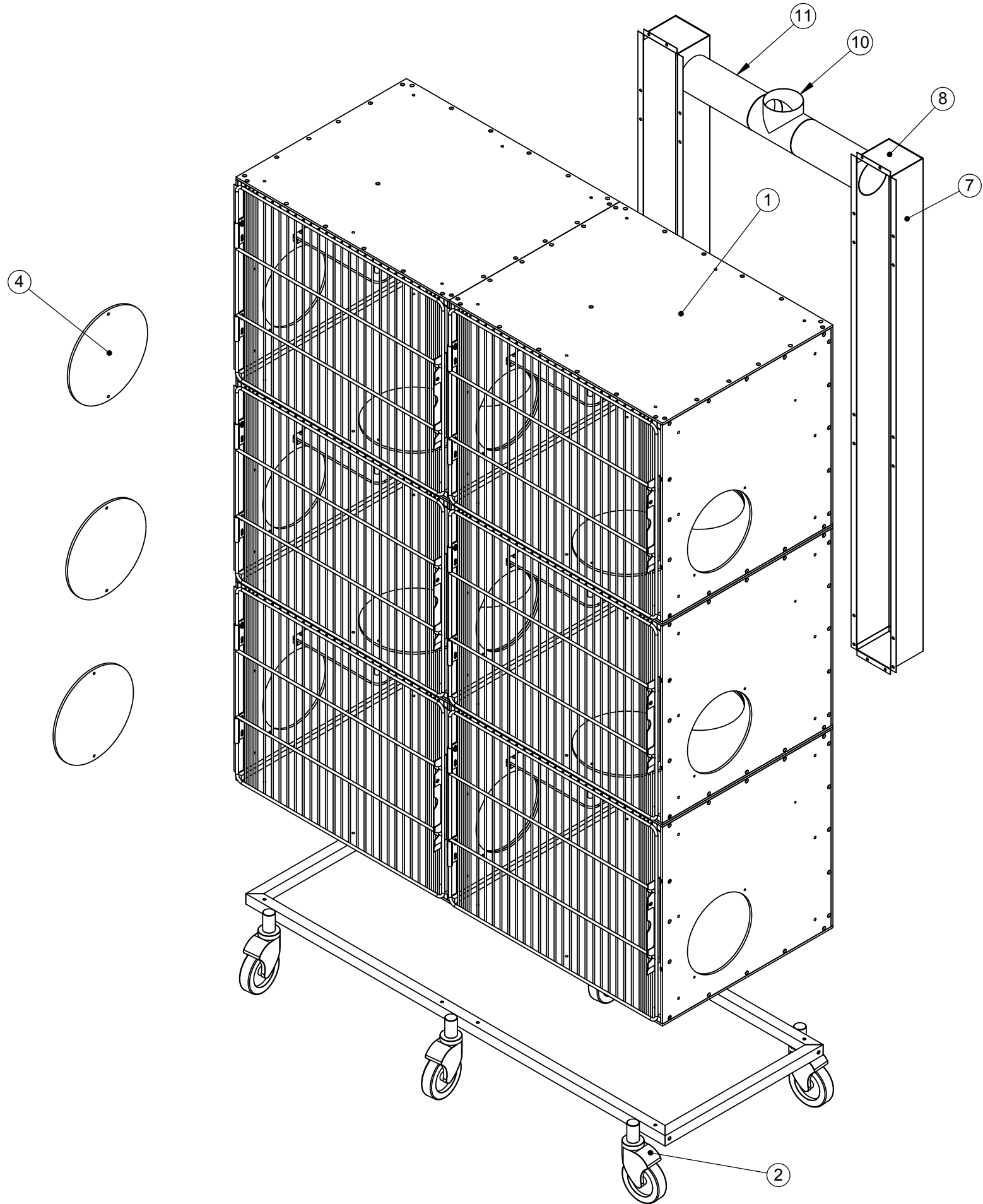

REV	DATE	DESCRIPTION	DRW	APP



Note:
1. #3, #5 and #6 are not shown

		LARSON SYSTEMS INC. 10073 Baltimore St. NE PH. 763-780-2131 Mpls., MN 55449 FAX. 763-780-2182	
		APPROVALS DRAWN DAL	DATE 03-25-06
APP. 		B	DWG. NO. 025-0000-0686-03
APP. 		SCALE: NONE	SHEET 1 OF 3

Standard 4" HVAC pipe connects to available flexible dryer hose to exhaust fan

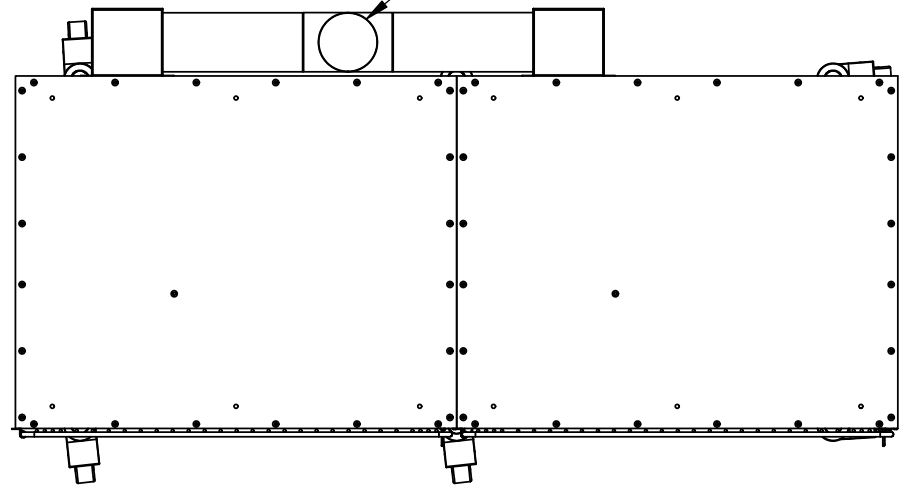

59.75

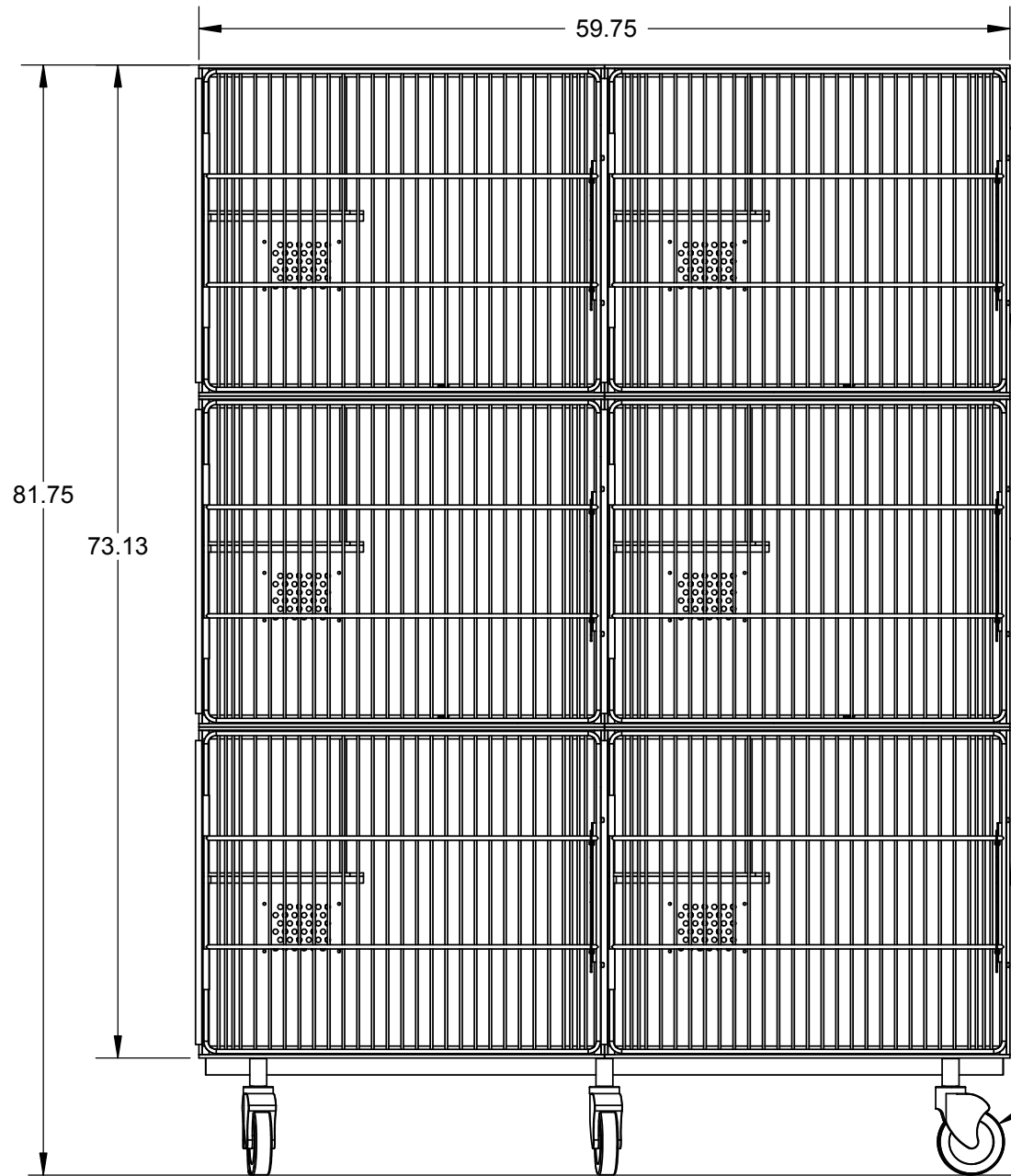

Configure as 2 three story condos for maximum space and feline interest with bedroom upstairs, dining room on the main floor and the bathroom downstairs

For holidays (when the Relatives come) configure as 6 individual spaces

Swivel locking casters for easy movement

29.63

25.07

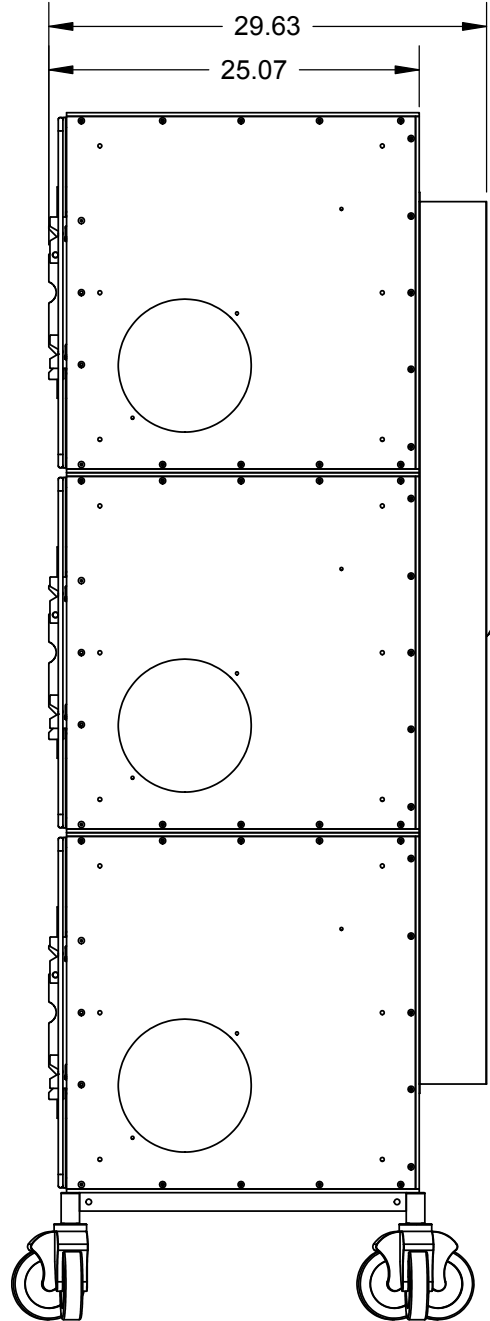

Compact size allows Condos to pass through a standard 7'x 3' door



LARSON SYSTEMS INC.

10073 Baltimore St. NE PH. 763-780-2131
Mpls., MN 55449 FAX. 763-780-2182